

**Фрезер СМТ за дърво профилен прав, без лагер ф 6x25.4/60
мм, ф 8 мм, 912**

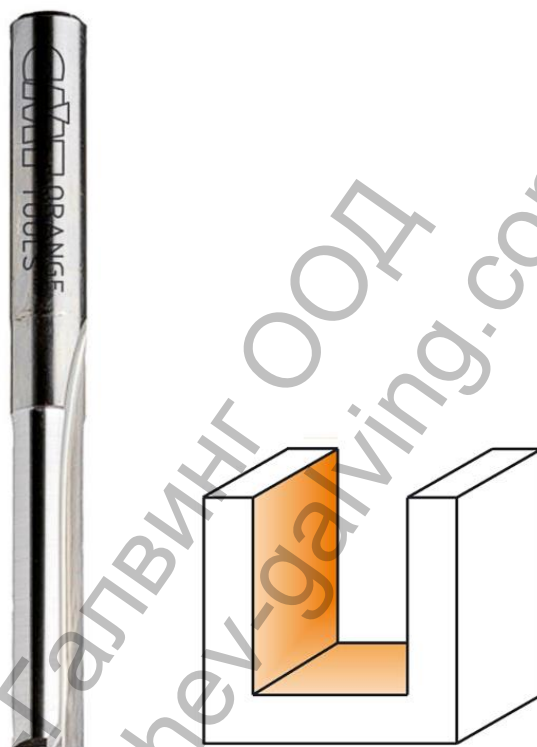

Ташев Галвинг ООД
www.tashev-galving.com

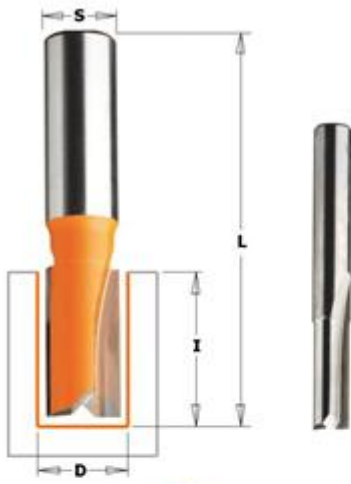

The cutting edge top sharpening on 9mm diameter bits and larger allows for short plunging operations.

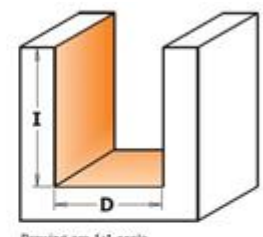

Drawing are 1:1 scale

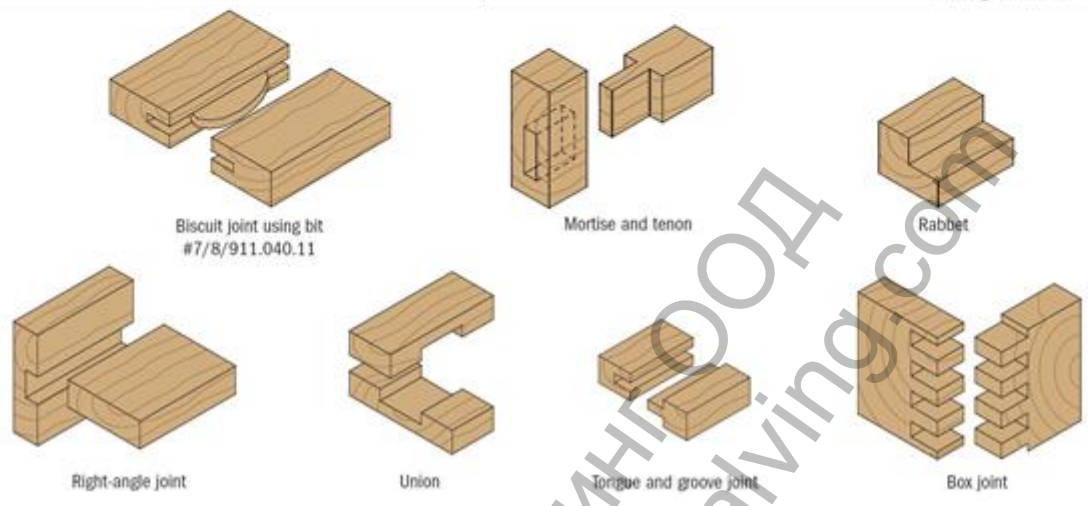

These razor-sharp, double-faced cutters perfectly synthesize the characteristics and advantages that define quality CMT products. Made of special Fatigue Proof® steel and micrograin carbide, our straight bits can withstand even the heaviest work load and still give you a smooth, precise cut every time. You also get exceptional chip ejection to allow cleaner and more constant cutting. The surface of all CMT bits is protected with our trademark orange non-stick PTFE to help keep the bit from collecting resin, pitch and other residue. Every bit is submitted to strict quality tests to guarantee perfect cutting tolerance, balance and concentricity. CMT bits allow production on an industrial scale using a variety of plywood, composites and natural woods. CMT produces 91 types of straight bits in a wide range of diameters so you can find exactly what you want.

- HW**
- HWM**
- Z1**
- Z2**
- RH**

Tungsten carbide
Tipped
Solid tungsten carbide
One cutting edge
Two cutting edges
Right-hand rotation

Ташевъ Технически Дарингъ
www.tachevtechnicaldriving.com

D mm	I mm	L mm	ORDER NO. S=Ø6mm	ORDER NO. S=Ø6,35mm	ORDER NO. S=Ø8mm	ORDER NO. S=Ø12mm	ORDER NO. S=Ø12,7mm
• 2*	4	38	711.020.11	811.020.11			
• 3	8	45	711.030.11	811.030.11	911.030.11		
• 3	8	58,3				911.530.11	
• 3,2	9,5	45		811.032.11			
• 4	10	58,3				911.540.11	
• 4	10	45	711.040.11	811.040.11	911.040.11		
• 4,75	12,7	50,8		811.047.11			
• 5	12	50,8	711.050.11	811.050.11	911.050.11		
• 5	12	58,3				911.550.11	
• 6	16	50,8	711.060.11	811.060.11	911.060.11		
• 6	19	60,3					811.560.11
• 6	19	65				911.560.11	
• 6,35	19	50,8		811.064.11			
• 6,35	19	57,2		811.065.11			
• 6,35	19	60,3					811.564.11
• 7	18	48	711.070.11	811.070.11	911.070.11		
• 7	18	65				911.570.11	
• 7,6	20	51				911.076.11	
• 8	20	48	711.080.11	811.080.11	911.080.11		
• 8	25,4	71,5		811.081.11			
• 8	25,4	70					811.581.11
9	20	48	711.090.11		911.090.11		
9,5	19	50,8		811.095.11			
9,5	25,4	63,5		811.096.11			
9,5	25,4	66,7					811.595.11
10	20	48	711.100.11	811.100.11	911.100.11		
10	25,4	63,5					811.600.11
11	20	48	711.110.11		911.110.11		
12	20	50	711.120.11	811.120.11	911.120.11		
12	25,4	63,5				911.620.11	811.620.11
12,3	25,4	57,2		811.123.11			
12,3	25,4	63,5					811.623.11
12,7	19	57,2		811.127.11			
12,7	25,4	66,7					811.627.11
12,7	31,7	82,5					811.628.11
13	20	57	711.130.11		911.130.11		
14	20	50	711.140.11	811.140.11	911.140.11		
14,2	14,2	57,2		811.142.11			
15	20	57,2	711.150.11	811.150.11	911.150.11		
15,8	19	66,7		811.158.11			
15,8	25,4	63,5					811.660.11
16	20	57,2	711.160.11	811.160.11	911.160.11		
16	25,4	63,5					811.661.11
17	20	50	711.170.11				
18	20	50	711.180.11	811.180.11	911.180.11		
18,2	25,4	57,2		811.182.11			
18,2	25,4	63,5					811.682.11
19	20	57,2	711.190.11	811.191.11	911.190.11		
19	25,4	63,5					811.690.11
20	20	50	711.200.11	811.200.11	911.200.11		
22	20	57,2	711.220.11	811.220.11	911.220.11		
24	20	50	711.240.11		911.240.11		
25	20	50	711.250.11		911.250.11		
25,4	19	50,8		811.254.11			
25,4	31,7	76,2					811.754.11
28,5	31,7	76,2					811.785.11

• HWM
• 71

Продукт: [Фрезер CMT за дърво профилен прав, без лагер ф 6x25.4/60 мм, ф 8 мм, 912](#)

Категория: [Консумативи за фрези и оберфрези](#)

Бранд: [CMT](#)

Категория бранд: [Фрезер CMT](#)